

Instructions for use

# Diversity Receiver EK 3041-U

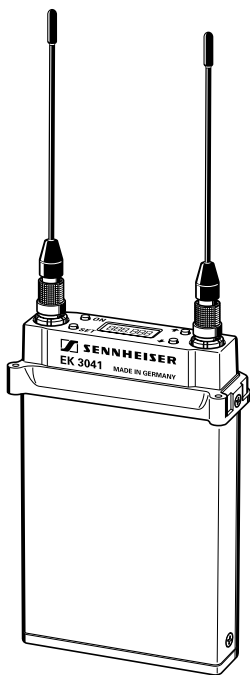

## Thank you for choosing Sennheiser!

We have designed this product to give you reliable operation over many years.

Please take a few moments to read these instructions carefully, as we want you to enjoy your new Sennheiser product quickly and to the full.

Chapter	Contents	Page
1	Brief description	29
2	Special features	29
3	Modes of application	29
4	Noise reduction with <b>HiDyn plus®</b>	30
5	Diversity reception	31
6	Connections and operating elements	32
7	Mounting the antennæ	33
8	Mounting the EK 3041-U into the Philips LDK 120	34
9	Mounting the EK 3041-U into the Ikegami HL-V77	35
10	Mounting the EK 3041-U into the Sony SX	36
11	Power supply	37
12	Putting the receiver into operation / Switching the receiver on	37
13	Switching the receiver off	37
14	Display of receiving frequency or channel number	38
15	Overview of menus	38
16	„Fast search“ function	39
17	Adjusting the headphone volume	40
18	Adjusting the squelch	41
19	Changing the receiving frequency	42
20	Assigning a channel number	43
21	Limiter	44
22	Locking the operating buttons / „Lock mode“ function	45
23	Sennheiser transmitters report their battery/accupack status	46
24	Suitable Sennheiser transmitters	47
25	Safety instructions	48
26	Error messages	48
27	Error checklist	48
28	Recommended accessories	49
29	Technical data	50

## 1 Brief description

The EK 3041-U is a miniature true diversity radiomicrophone receiver designed for use with the new digital ENG camcorders. It can be inserted in the slot-in facility of most professional camcorders such as the Philips LDK 120, Ikegami HI-77 or Sony SX. Together with a suitable Sennheiser UHF pocket or hand-held transmitter, a highly reliable radio link can be set up.

Annoying noise is effectively suppressed by **HiDyn plus®**, the Sennheiser noise reduction system.

Interchangeable mounting kits (for mounting the receiver into camcorders) ensure suitability for a great variety of applications.

## 2 Special features

- Compact design
- Robust all-metal housing
- Easy to use due to menu-assisted operation
- Up to 32 pre-programmed receiving frequencies
- High transmission reliability due to true diversity reception
- **HiDyn plus®** noise reduction system with more than 100 dB signal-to-noise ratio
- Powered via camcorder or GA 3041-B power adaptor
- Indication of transmitter battery status\* („Low battery“)
- Mounting kits available for all current professional camcorders
- Weather-proof and therefore suitable for outdoor applications

## 3 Modes of application

The EK 3041-U can be

- used as a „slot-in“ receiver inserted in the slot-in facility of professional camcorders
- inserted in a special housing for attachment to camcorders without slot-in facility

\* only with Sennheiser transmitters transmitting battery status information

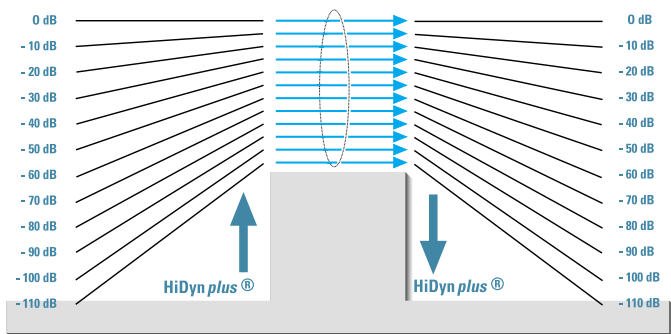

#### 4 Noise reduction with HiDyn plus®

This receiver is equipped with **HiDyn plus®**, the Sennheiser noise reduction system that reduces RF interference. It increases the signal-to-noise ratio in wireless audio transmission to more than 100 dB.

**HiDyn plus®** is a wideband compander system which compresses the AF level on the transmitter side in a ratio of 2:1 (related to dB), and expands it in an exactly the same way on the receiver side. The optimisation of the dynamic range and the supporting effect of the control amplifier in the transmitter effectively reduce modulation problems.

**HiDyn plus®** has been specially developed for use in high quality radiomicrophone systems.

#### Note

Only transmitters which are also equipped with **HiDyn plus®** can work correctly in combination with the EK 3041-U receiver. If this is not the case, the dynamic range is drastically reduced and the transmission sounds blunt and flat. **HiDyn plus®** cannot be switched off on the EK 3041-U receiver.

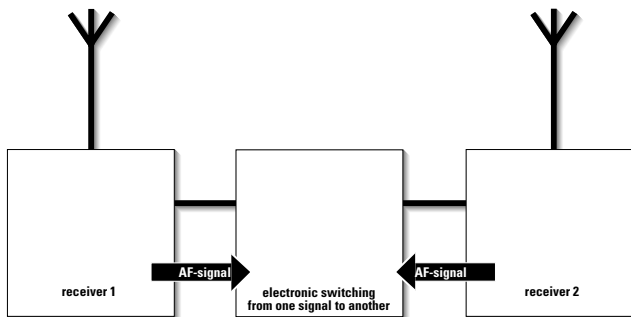

## 5 Diversity reception

The EK 3041-U receiver operates on the „true diversity“ principle:

A receiving antenna receives not only the electromagnetic waves which reach it by a direct path, but also the reflections of these waves which are created in the room by walls, windows, ceilings and fittings. When these waves are superimposed, destructive interference occurs, which can also be called „field strength gaps“. Repositioning the receiving antenna can bring a solution, provided the transmitter remains in its original position. With mobile transmitters and receivers, however, the „field strength gap“ will then occur with a different transmitter or receiver position. These field strength gaps“ can only be eliminated with true diversity receivers.

In true diversity, instead of one antenna and one receiver there are now two antenna and two receiver sections. The antenna are spatially separated. By means of a comparison circuit, the receiver section with the strongest RF signal is always switched to the common AF output. The switching is inaudible. True diversity makes sense because, at UHF frequencies, even antenna placed only a few centimetres apart provide effective protection against interference caused by „field strength gaps“. The risk of the occurrence of field strength gaps“ in both antenna at the same time is virtually nonexistent.

## 6 Connections and operating elements

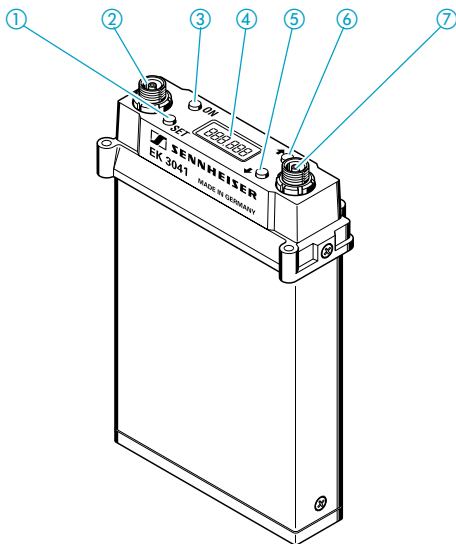

- ① SET button for menu selection and programming
- ② Antenna socket, diversity branch A
- ③ ON / OFF switch
- ④ Multi-function display panel
- ⑤ Button for adjusting the settings of a selected menu (cycling downwards)
- ⑥ Button for adjusting the settings of a selected menu (cycling upwards)
- ⑦ Antenna socket, diversity branch B

## 7 Mounting the antennæ

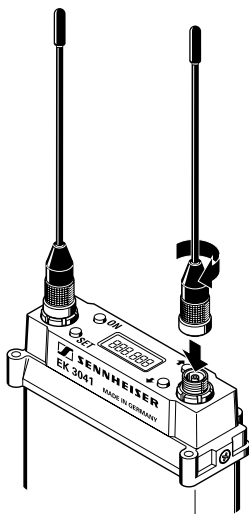

Your EK 3041-U receiver is supplied with two antenna which are necessary for true diversity operation (see chapter 5). The length of the antenna has been matched to the frequency range of your EK 3041-U receiver.

**Insert the antenna into sockets ② and ⑦ and screw them tight.**

## 8 Mounting the EK 3041-U into the Philips LDK 120 camcorder

### Preparation:

Mount the base plate suitable for the Philips camcorder and fix it to the left and right of the receiver by means of two screws. The Philips adaptor features a 44-pin connector (accessories).

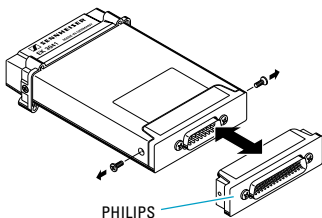

### Mounting the receiver into the camcorder:

- Fix the receiver (from above) to the mounting frame by means of four small screws.
- Insert the receiver in the slot-in facility until the 44-pin connector securely connects.
- Fix the receiver to the slot-in facility by means of the two knurled screws.

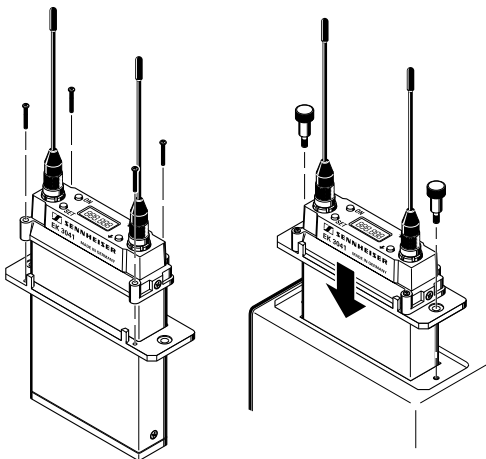



## 9 Mounting the EK 3041-U into the Ikegami HL-V77 camcorder

### Preparation:

Mount the base plate suitable for the Ikegami camcorder and fix it to the left and right of the receiver by means of two screws. The Ikegami adaptor features a 25-pin connector (accessories).

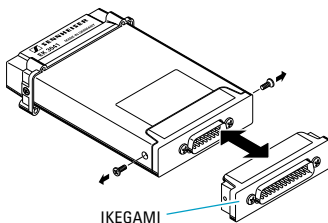

### Mounting the receiver into the camcorder:

- Screw the mounting frame to the Ikegami camcorder housing.
- Insert the receiver in the slot-in facility until the 25-pin connector securely connects.
- Fix the receiver (from above) to the mounting frame by means of four small screws.

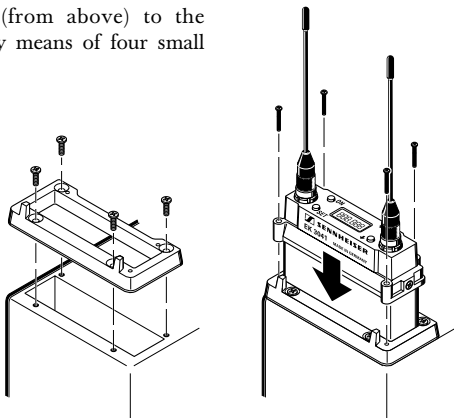

## 10 Mounting the EK 3041-U into the Sony SX camcorder

### Preparation:

Mount the base plate suitable for the Sony camcorder and fix it to the left and right of the receiver by means of two screws.

The Sony adaptor features a 15-pin connector (accessories).

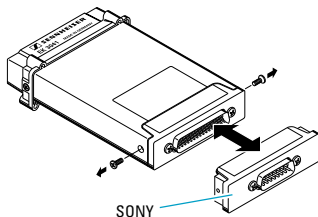

### Mounting the receiver into the camcorder:

- Screw the mounting frame to the Sony camcorder housing.
- Insert the receiver in the slot-in facility until the 15-pin connector securely connects.
- Fix the receiver (from above) to the mounting frame by means of four small screws.

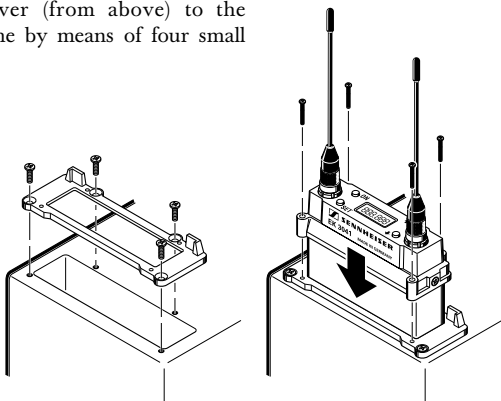

## 11 Power supply

Your EK 3041-U receiver can be powered from different power sources. The adaption to these power sources is via the plug-in connector at the bottom of the receiver and the corresponding accessories.

The EK 3041-U can be powered

- directly via the camcorder with 12 V or 5.6 V or
- via the GA 3041-B power adaptor which is attached to the special housing

## 12 Putting the receiver into operation / Switching the receiver on

If the receiver is inserted in the slot-in facility of a camcorder, the receiver is switched on as soon as the camcorder is put into operation. The receiver's ON/OFF switch ② is then locked. If the ON/OFF switch is pressed, „Loc“ appears on the display.

If the receiver is mounted into a special housing for external attachment to camcorders, press the ON/OFF switch ② to switch the receiver on. After approx. two seconds, the display indicates the receiving frequency or its respective channel number.

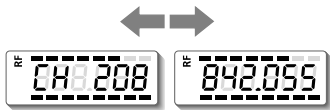

Two bargraphs indicate the received RF signal (upper bargraph: „RF“) and the deviation (lower bargraph).

## 13 Switching the receiver off

To switch the receiver off, press the ON/OFF switch ② for approx. one second until „OFF“ briefly appears on the display.

Please wait at least two seconds before switching the receiver on again.

## 14 Display of receiving frequency or channel number

You can choose the content of the display i.e. whether the preselected receiving frequency or its respective channel number is indicated.



To do so, please proceed as follows:

- ▶ If you press button ▲, the preselected receiving frequency is indicated.
- ▶ If you press button ▼, the respective channel number is indicated.

Information on how to change the receiving frequency is given in chapter 19, information on how to assign a channel number can be found in chapter 20.

## 15 Overview of menus

Despite its small dimensions, the EK 3041-U features an easy-to-use operating menu comprising six menus with extensive adjustment facilities. The menus can be selected by means of the SET button.

Detailed information on the menus is given in chapters 17 to 22. The following is just an overview:

- ▶ **Press the SET button once**  
to adjust the headphone volume. This menu is skipped (= out of operation) if the receiver is inserted into a camcorder (➡ see chapter 17).
- ▶ **Press the SET button twice**  
to adjust the squelch (➡ see chapter 18).

- ▶ **Press the SET button three times**  
to select a receiving frequency (➡ see chapter 19).
- ▶ **Press the SET button four times**  
to assign a channel number to a receiving frequency (➡ see chapter 20).
- ▶ **Press the SET button five times**  
to adjust the limiter of the headphone output. This menu is skipped (= out of operation) if the receiver is inserted into a camcorder (➡ see chapter 21).
- ▶ **Press the SET button six times**  
to lock the operating buttons! The „lock mode“ function protects your receiver against operating errors (➡ see chapter 22).
- ▶ **Press the SET button seven times**  
to return to normal operation. If desired, you can start to adjust the settings over again.

### Cancellation

After about 15 seconds, the receiver automatically returns to normal operation if no entry has been made during this period. You can discontinue your entry at any time by briefly pressing the ON/OFF switch.

## 16 „Fast search“ function

The ▲/▼ buttons feature a „fast search“ function. If you hold down a button, the cycling of the display is continuously accelerated. If you release the button and start over again, the cycling of the display restarts at normal speed.

The „fast search“ function allows you to get fast and easily to your desired setting.

## 17 Adjusting the headphone volume

- ▶ Briefly press the SET button **once**.

The display now indicates „PHonE“ in alternation with a three-digit number indicating the current volume level at the headphone output of your EK 3041-U receiver. The adjustment range of the headphone volume is between 0 and 126 (on the display).

- ▶ The headphone output can only be used if the receiver is not inserted in the slot-in facility of a camcorder but is operated as a stand-alone receiver, e.g. inserted into a special housing (accessory). If the receiver is inserted in the slot-in facility of a camcorder, the headphone volume cannot be adjusted and the menu is skipped.



- ▶ With the ▲ / ▼ buttons you can now select a different volume setting. Selecting a smaller value reduces the volume, selecting a higher value increases the volume.
- ▶ The new setting becomes effective immediately without having to be stored.

### Notes

- ▶ You can discontinue the programming of this menu at any time. Press the SET button to change to the next menu or **briefly** press the ON/OFF switch to discontinue your entry. The cancellation is briefly confirmed on the display with „ESC“. The display then switches back to the standard display (display of receiving frequency or channel number) (see chapter 16).
- ▶ After about 15 seconds, the receiver automatically returns to normal operation if no entry has been made during this period. Here, too, „ESC“ flashes briefly.

## 18 Adjusting the squelch

Your EK 3041-U receiver is equipped with an adjustable squelch control which eliminates annoying noise when the transmitters are switched on and off. It also suppresses sudden noise when a transmitter leaves the reception area and there is no longer sufficient transmitter power received by the receiver.

- ▶ Briefly press the SET button **twice**.

The display now indicates „Squelch“ in alternation with one of nine possible squelch values (adjustable in 5-dB steps from „OFF“ to „40“). These values are – to some extent – comparable to an input voltage in dB  $\mu$ V.



- ▶ With the  $\blacktriangle$  /  $\blacktriangledown$  buttons you can now select a different setting. Selecting a smaller value reduces the squelch threshold, selecting a higher value increases the squelch threshold.
- ▶ The new setting becomes effective immediately without having to be stored.

### Notes

- ▶ You can discontinue the programming of this menu at any time. Press the SET button to change to the next menu or **briefly** press the ON/OFF switch to discontinue your entry. The cancellation is briefly confirmed on the display with „ESC“. The display then switches back to the standard display (display of receiving frequency or channel number) (see chapter 16).
- ▶ After about 15 seconds, the receiver automatically returns to normal operation if no entry has been made during this period. Here, too, „ESC“ flashes briefly.

## 19 Changing the receiving frequency

- ▶ Briefly press the SET button **three times**. The display now indicates the preset receiving frequency in alternation with the channel number assigned. (If no channel number has been assigned, three „hyphens“ appear on the display):



- ▶ With the ▲ / ▼ buttons you can now select a different frequency. The display always jumps to the next fixed frequency setting in the program.
- ▶ When you get to the desired frequency, press the SET button for about 1 second. Your entry is confirmed by the fact that „Sto“ briefly appears on the display.

**Only now does the receiver change to the new frequency**, any existing RF link to a transmitter on the previous frequency is interrupted. The display then switches back to the preset standard display (display of receiving frequency or channel number) (➡ see chapter 16).

### Notes

- ▶ You can discontinue the programming of this menu at any time. Press the SET button to change to the next menu or **briefly** press the ON/OFF switch to discontinue your entry. The cancellation is briefly confirmed on the display with „ESC“. The display then switches back to the standard display (➡ see chapter 16).
- ▶ After about 15 seconds, the receiver automatically returns to normal operation if no entry has been made during this period. Here, too, „ESC“ flashes briefly.



## 20 Assigning a channel number

You can assign a channel number (from 001 to 255) to each of the 32 receiving frequencies. With larger systems, it is recommended to use the same channel number for both transmitters and receivers in order to provide for simpler monitoring of the system.

- ▶ Briefly press the SET button **four times**.

The display now indicates the assigned channel number in alternation with „CH SET“. (If no channel number has been assigned, three „hyphens“ appear on the display):



- ▶ With the ▲/▼ buttons you can now select the desired channel number.
- ▶ When you get to the desired channel number, press the SET button for about 1 second. Your entry is confirmed by the fact that „Sto“ briefly appears on the display.

The display then switches back to the preset standard display (display of receiving frequency or channel number) (☛ see chapter 16).

### Notes

- ▶ You can discontinue the programming of this menu at any time. Press the SET button to change to the next menu or **briefly** press the ON/OFF switch to discontinue your entry. The cancellation is briefly confirmed on the display with „ESC“. The display then switches back to the standard display (☛ see chapter 16).
- ▶ After about 15 seconds, the receiver automatically returns to normal operation if no entry has been made during this period. Here, too, „ESC“ flashes briefly.

## 21 Limiter

Your EK 3041-U receiver is equipped with a switchable limiter which limits the output voltage of the built-in headphone amplifier. The limiter protects your hearing and should therefore always be switched on.

### Note

The limiter can only be used if the receiver is **not** inserted in the slot-in facility of a camcorder but is operated as a stand-alone receiver, e.g. inserted into a special housing (accessory). If the receiver is inserted in the slot-in facility of a camcorder, this menu is skipped.

- ▶ Briefly press the SET button **five times**.

The display now indicates „-Ltd.-“ in alternation with the current limiter setting, for example:

- „**Ltd.OFF**“, if the limiter is switched off,
- „**Ltd.-10**“, if the limiter is set to - 10 dB,
- „**Ltd.-20**“, if the limiter is set to - 20 dB.



- ▶ With the ▲ / ▼ buttons you can now select the desired limiter setting.
- ▶ The new setting becomes effective immediately without having to be stored.

### Notes

- ▶ You can discontinue the programming of this menu at any time. Press the SET button to change to the next menu or **briefly** press the ON/OFF switch to discontinue your entry. The cancellation is briefly confirmed on the display with „ESC“. The display then switches back to the standard display (display of receiving frequency or channel number) (see chapter 16).
- ▶ After about 15 seconds, the receiver automatically returns to normal operation if no entry has been made during this period. Here, too, „ESC“ flashes briefly.

## 22 Locking the operating buttons / „Lock mode“ function

You can lock the operating buttons of your EK 3041-U to prevent accidental programming or switching off by a user inexperienced in handling the receiver.



### Locking the buttons

- ▶ Briefly press the SET button **six times** until „Loc“ begins to flash on the display.
- ▶ Now press the SET button for **more than** one second to store your setting. „Sto“ briefly appears on the display, indicating that the new setting has been stored. The display then switches back to the standard display.

The buttons are now locked. If they are accidentally pressed, the display briefly indicates „Loc“ and then switches back to the standard display. With the ▲/ ▼ buttons, however, you can still choose the content of the display i.e. whether the transmission frequency or the channel number is displayed.

### Unlocking the buttons

- ▶ Briefly press the SET **once**. „Loc“ begins to flash on the display.
- ▶ Now press the SET button for more than one second.

The display switches back to the standard display and the buttons can now be operated as usual.

## 23 Sennheiser transmitters report their battery/accupack status

Sennheiser supplies hand-held and pocket transmitters (➡ see chapter 24) which provide information on the available transmitter battery/accupack status to the receiver. This information can be evaluated with the EM 3041-U receiver.



- ▶ When the battery or accupack capacity is so low that only a transmission time of about 20 to 30 minutes remains, the „bat.tr“ display – alternating with the display of the receiving frequency or channel number – begins to flash on the display.

You should now immediately replace the transmitter battery or accupack.

### Note

- ▶ The „bat.tr“ display is reset by the mute function (➡ see chapter 16). Whenever the squelch is activated in the EK 3041-U receiver, the „bat.tr“ display goes off and the evaluation of the battery status signal from the transmitter starts over again.

Under normal reception conditions, the evaluation of the battery information from the transmitter lasts about 10–20 seconds.

## 24 Suitable Sennheiser transmitters

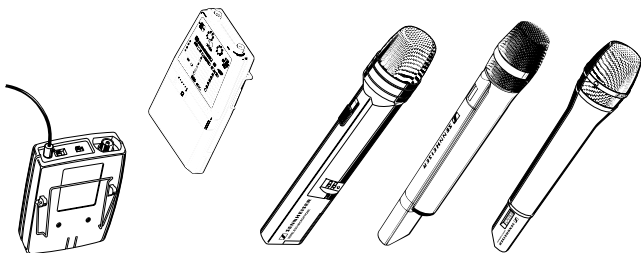

For the optimum use of the excellent reception qualities of the EK 3041-U receiver, Sennheiser offers hand-held and pocket transmitters in a variety of configurations:

### Pocket transmitters:

- SK 1063-U (without display of battery status)
- BF 1083-U (without display of battery status)
- SK 50-U (with display of battery status)
- SK 50-UA (with display of battery status)
- SK 250-U (with display of battery status)

### Hand-held transmitters:

- SKM 1072-U (without display of battery status)
- BF 1081-U (without display of battery status)
- SKM 3072-U (with display of battery status)
- SKM 5000-U (with display of battery status)

Information on the many possible combinations of Sennheiser products and their use in multi-channel systems can be found in the planning brochure „Practical Applications in RF Technology“ which your Sennheiser distributor has in stock or will be pleased to order for you from Sennheiser.

For up-to-date information on Sennheiser products, you can also visit the Sennheiser Web site at „<http://www.sennheiser.com>“.

## 25 Safety instructions

- ▶ Never open electronic devices! Servicing and programming must only be done by authorised personnel and is all the more important for current-carrying units. If devices are opened by customers in breach of this instruction, the warranty becomes null and void.
- ▶ Keep the receiver away from central heating radiators and electric heaters.
- ▶ Use a damp cloth for cleaning the receiver. Do not use any cleansing agents or solvents.

## 26 Error messages

The display of the receiver is also used by the integrated microprocessor to display error messages for service purposes. If you see error messages such as „EE\_DEF“ or „rS\_232“, there is a fault in the receiver unit which can only be corrected by your local Sennheiser service department.

## 27 Error checklist

<b>Error</b>	<b>Possible cause</b>
Receiver does not work; display panel dark	▶ Check the camcorder's power supply; if necessary, switch power supply on separately
Receiver does not work; display panel lit up	▶ Frequency of transmitter does not agree with receiving frequency ▶ Squelch threshold adjusted too high
Sound distorted	▶ Transmission microphone over- modulated; reduce AF level or transmitter sensitivity
Sound overlaid with background noise	▶ Transmitter not sensitive enough; where appropriate, increase transmitter sensitivity

## 28 Recommended accessories

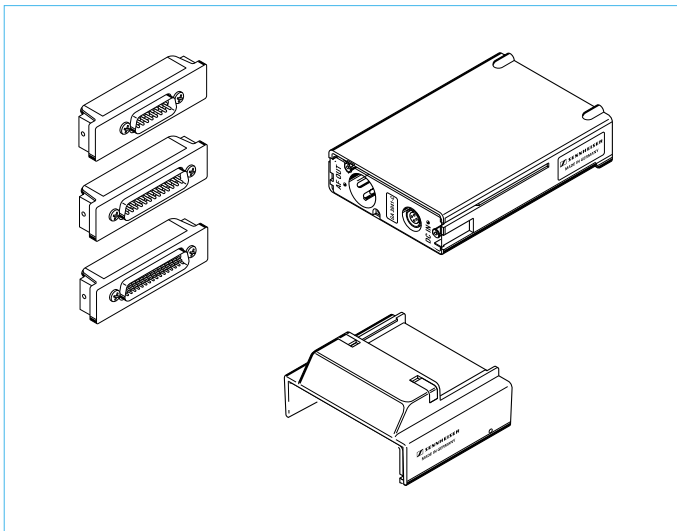

- |              |                                 |                |
|--------------|---------------------------------|----------------|
| • GA 3041-C  | Base plate with special housing | Cat. no. 04642 |
| • GA 3041-B  | Power adaptor                   | Cat. no. 04643 |
| • GA 3041-15 | Sony adaptor                    | Cat. no. 04639 |
| • GA 3041-25 | Ikegami adaptor                 | Cat. no. 04640 |
| • GA 3041-44 | Philips adaptor                 | Cat. no. 04641 |
| • B 50       | Battery box (small)             | Cat. no. 03545 |
| • B 250      | Battery box (large)             | Cat. no. 03547 |
| • BA 50      | Accupack (small)                | Cat. no. 03546 |
| • BA 250     | Accupack (large)                | Cat. no. 03548 |

## 29 Technical data

Frequency range	450–960 MHz
Receiver frequencies	max. 32, pre-programmed to customer specifications
Switching bandwidth	24 MHz
Frequency stability	$\pm 10$ ppm ( $-10$ °C to $+55$ °C)
Sensitivity (with <b>HiDyn plus®</b> )	typ. $10$ $\mu$ V for 90 dBA rms SNR
Squelch threshold	0 to 100 $\mu$ V, adjustable in 5-dB steps
Adjacent channel rejection	$\geq 70$ dB
Intermodulation attenuation	$> 70$ dB (400 kHz/800 kHz)
Antenna inputs / Impedance	2 LEMO sockets / 50 $\Omega$
Companer system	Sennheiser <b>HiDyn plus®</b>
De-emphasis	50 $\mu$ s
Nominal/peak deviation	$\pm 40$ kHz/ $\pm 56$ kHz
AF frequency response	50–20,000 Hz
Signal-to-noise ratio	$\geq 100$ dB(A) at 1 mV <sub>RF</sub> and peak deviation
Outputs / Power supply	plug-in connector mounted at the bottom. The connections depend on the different mounting adaptors:
▶ via GA 3041-C:	
AF output	3-pin XLR + 9 dB (2.2 V rms), electronically balanced, standard wiring at pin 2 and 3, + at pin 2, 3 screen/ground $\leq 10$ k $\Omega$
Terminating impedance	
Power supply	via 4-pin „HIROSE“ DC-socket HR 10-7-R45, pin 1: ground, pin 4 10.5–18 V DC, approx. 40 mA at 12 V
▶ via GA 3041-B:	
Power supply	1.8–4.8 V (internally DC/DC adjusted to max. 3.2 V), approx. 150 mA at 2.4 V
Suitable accupacks	Sennheiser BA 50 and BA 250
Suitable battery boxes	Sennheiser B 50 and B250
Limiters (at headphone output only)	switchable: $-10$ dB and $-20$ dB
THD at 1 kHz and nominal deviation	$\leq 1$ %, typ. 0.8 % for overall device
Temperature range	$-10$ °C to $+55$ °C
Dimensions / Weight	120 x 74 x 28 mm / approx. 200 g
In compliance with	ETS 300422



Aktuelle Informationen zu Sennheiser-Produkten erhalten Sie auch im Internet unter „<http://www.sennheiser.com>“.

Up to date information on Sennheiser products can also be found on the Internet under “<http://www.sennheiser.com>”.

Vous trouverez également toutes les informations actuelles relatives aux produits Sennheiser sur Internet, sous “<http://www.sennheiser.com>“.

Informazioni attuali sulla gamma di prodotti Sennheiser sono disponibili anche in Internet al sito „<http://www.sennheiser.com>“.

También en Internet, bajo „<http://www.sennheiser.com>“ obtendrá Vd. informaciones actuales sobre los productos Sennheiser.

Actuele informatie met betrekking tot Sennheiser producten vindt u ook op Internet onder “<http://www.sennheiser.com>“.

Änderungen vorbehalten

Subject to alterations

Sous réserve de modification

Con riserva di modifiche

Reservado el derecho a introducir modificaciones

Wijzigingen voorbehouden



Sennheiser electronic GmbH & Co. KG

D-30900 Wedemark

Telefon: +49 (0) 5130 600 0

Telefax: +49 (0) 5130 600 300

Printed in Germany

Publ. 04/98

69668 / A 01